



操作指南 **O** PERATOR'S GUIDE

F系列调距叉 F-Series Fork Positioners



官方微信号 天猫旗舰店

 服务热线
Customer Service Hotline

40088 57315

目录 CONTENTS



介绍	Introduction	1
用户注意事项	End User Please Notice	2
安全规则	Safety Rules	3
调距叉操作	Fork Position Operation	6
日常检查	Daily Inspection	7
定期维护保养	Periodic Maintenance	8
备件清单	Spare Part List	10
安全操作和维护	Safe Operation and Maintenance (OSHA Regulations)	12
质量保证政策	Warranty	16



警告: 叉车属具综合承载能力是由叉车制造厂决定, 其值可能比属具铭牌上的小, 请参见叉车铭牌。

注意: 操作者必须是经过培训且授权的人员。

WARNING: Rated capacity of the truck/attachment combination is a responsibility of the original truck manufacturer and may be less than shown on the attachment nameplate. Consult the truck nameplate.

CAUTION: Do not operate this attachment unless you are a trained and authorized lift truck driver.

注意: 本指南阐述对大多数货物工况的作业规则。特殊情况, 请向您的上级主管请教具体的正确操作规则。

CAUTION: This Guide shows recommended load handling procedures applicable to most products. Consult your company or organization for any special procedures applicable to loads you.

介绍 / INTRODUCTION

本手册为F系列调距叉的操作指南,旨在帮助您在操作中避免属具及货物的损伤,操作前请仔细阅读本手册,掌握所有的操作步骤及安全规则,不详之处请向您的上级请教。

安全第一!——大多数事故都起因于操作或判断失误,请格外留心维护保养状况差 工况恶劣的属具并及时加以解决。

This guide contains operating instructions for Cascade F-Series Fork Positioner. It will help avoid common errors which often cause damage to the equipment or product being handled. Read this manual thoroughly before operating the attachment. Be sure you know and understand all operating procedures and safety precautions. If you have any questions, or don't understand a procedure, ask your supervisor.

Emphasize Safety! Most accident are caused by operator carelessness or misjudgement. You must watch for hazardous situations and correct them.

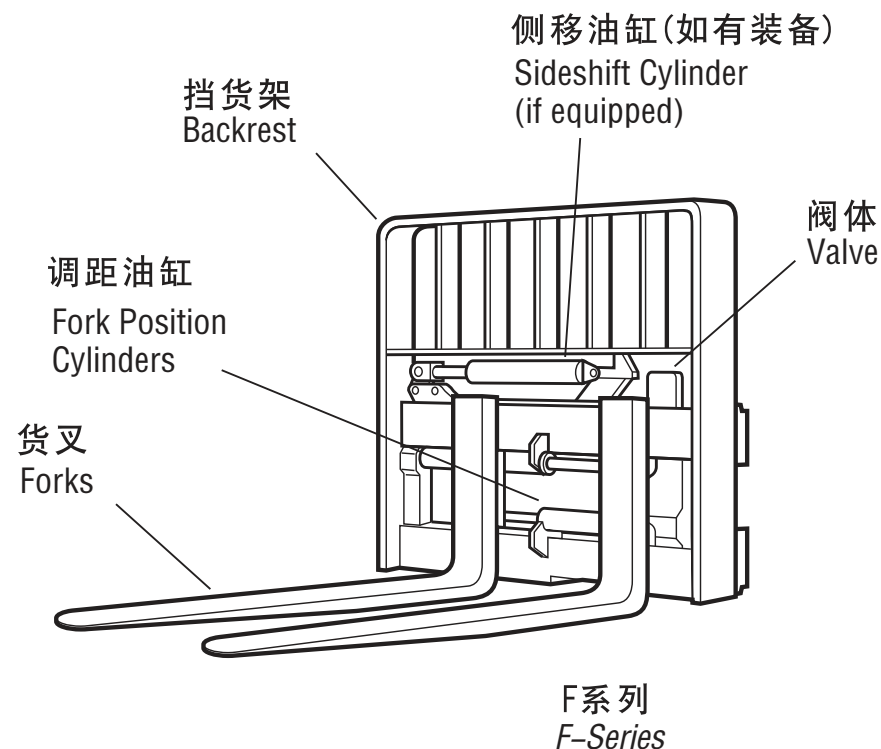



日常的维护保养对于保证叉车属具产品的正常功能及使用寿命至关重要，详细事项请参见卡斯卡特叉车属具《操作指南》或《维修手册》，或者请首先向售出该产品的叉车主机厂或其代理商咨询。

卡斯卡特（厦门）公司也非常乐意回答您在这方面任何感兴趣的问题。

The daily inspection and periodic maintenance is very important for ensuring the normal performance and durable service life of the forklift truck attachment. For details, please consult the Cascade Xiamen forklift truck attachment 《Operator's Guide》 or 《Service Manual》.

You could also primarily consult the forklift truck OEM or its Dealer from whom you purchased this equipment. Of course, Cascade Xiamen is willing to answer any questions of your interest, too.

卡斯卡特（厦门）叉车属具有限公司
服务与配件处
电话：4008857315
传真：86-592-6512571

Customer Service Department,
Cascade Xiamen Forklift Truck Attachment Co., Ltd.
Phone tel:4008857315 Fax:86-592-6512571

安全规则-叉车 Safety Rules-Forklift Trucks

禁止载人行驶
No Riders



禁止伸手穿过门架
No Reaching Through Mast



禁止货物下站人
No Standing under load



在装载时前后倾
Tilt when traveling loaded



关闭发动机，制动，降下货叉
Motor off, park, lower load

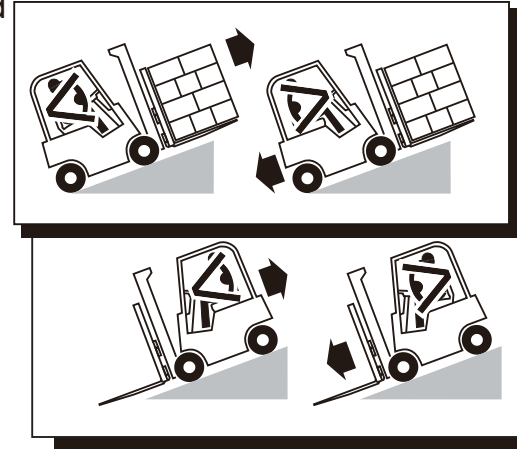



禁止坡上停车
No Parking On Ramp



禁止坡上转弯
No Turning On Ramp

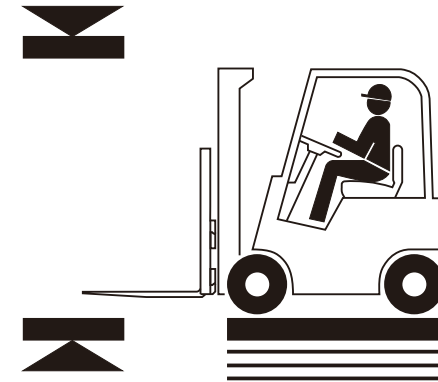

注意行驶空间
No Turning On Ramp

交通标志 TRAFFIC



工作人员
Workers



停止
Stop



凸起
Bumps



凹坑
Dips



双向行驶时
必须慢行
Slow for two-way traffic

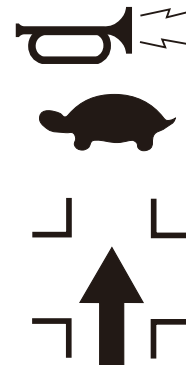

十字路口处
鸣笛，慢行
Sound horn, slow at intersection

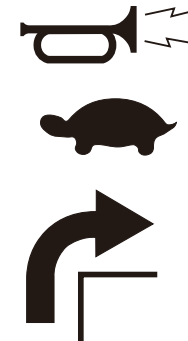

转弯时必须
鸣笛，慢行
Sound horn, slow at corner

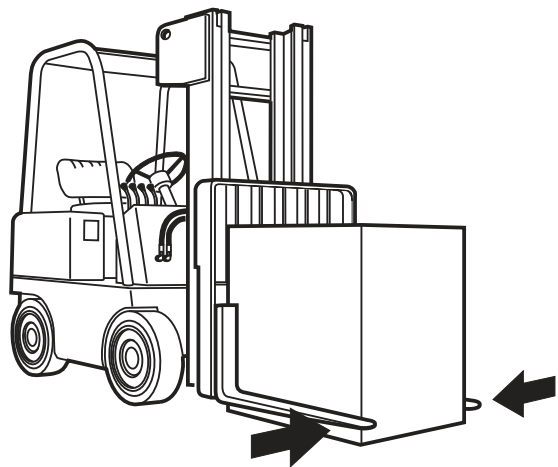

注意：不能用单个货叉挑货物
CAUTION: Do not clamp load with forks.

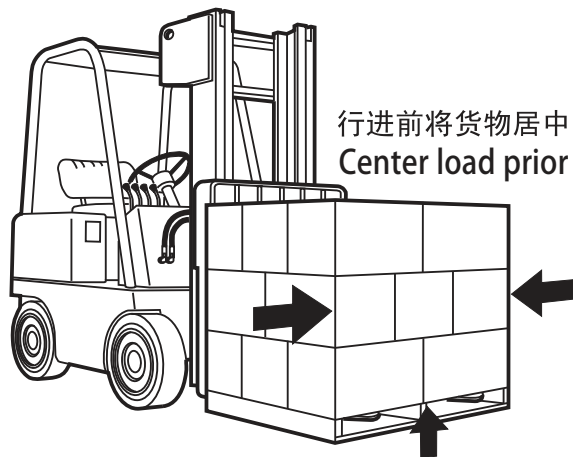

行进前将货物居中
Center load prior to traveling.

举升货物后再侧移
Raise load prior to sideshifting

举升货物时避免过分侧移
Limit sideshifting with raised load.

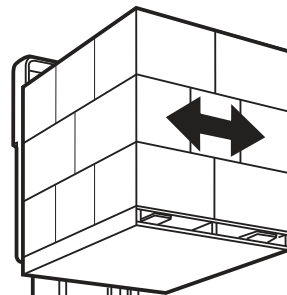

举升货物时叉车应限速行驶
Limit truck movement with raised load.

货物顶部不超过挡货架
Top of load should not extend above backrest.

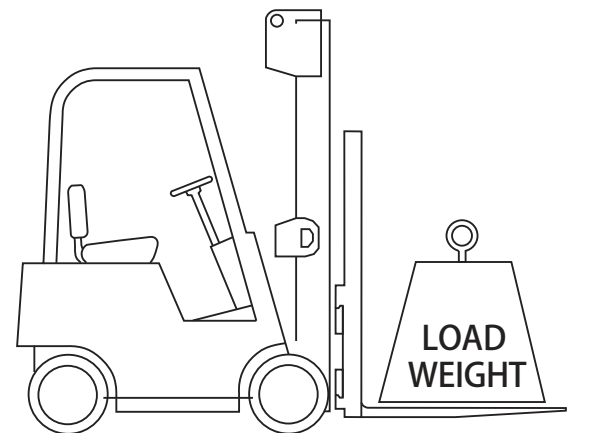
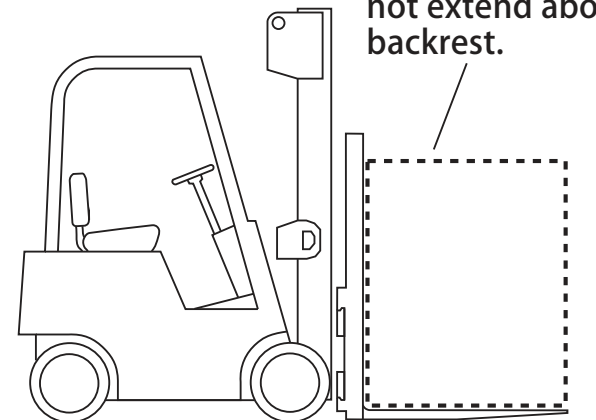

货物重量必须小于叉车/属具组合承载能力（见叉车铭牌）
Load weight must not exceed combined truck/attachment capacity(see truck nameplate)
左右货叉总承载能力必须大于货物重量
Total fork capacity(LH+RH fork) must be greater than load weight. Check



**带标准阀装置
FORK POSITIONER WITH
STANDARD VALVE**

- A 左侧移 Sideshift Left
- B 右侧移 Sideshift Right
- C 货叉分开 Forks Out
- D 货叉并拢 Forks In

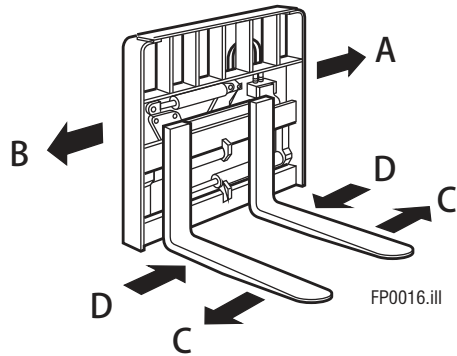

**带顺序阀装置
FORK POSITIONER WITH
SEQUENCE VALVE**

- A 左侧移-货叉分开 Sideshift Left-Forks Out
- B 右侧移-货叉并拢 Sideshift Right-Forks In

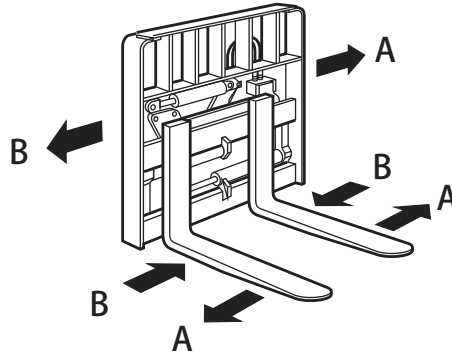

**带电磁阀装置
FORK POSITIONER WITH
SOLENOID VALVE**

- A 左侧移 Sideshift Left
- A 货叉分开 (按住按钮)
Forks Out (press knob button)
- B 右侧移 Sideshift Right
- B 货叉并拢 (按住按钮)
Forks In (press knob button)

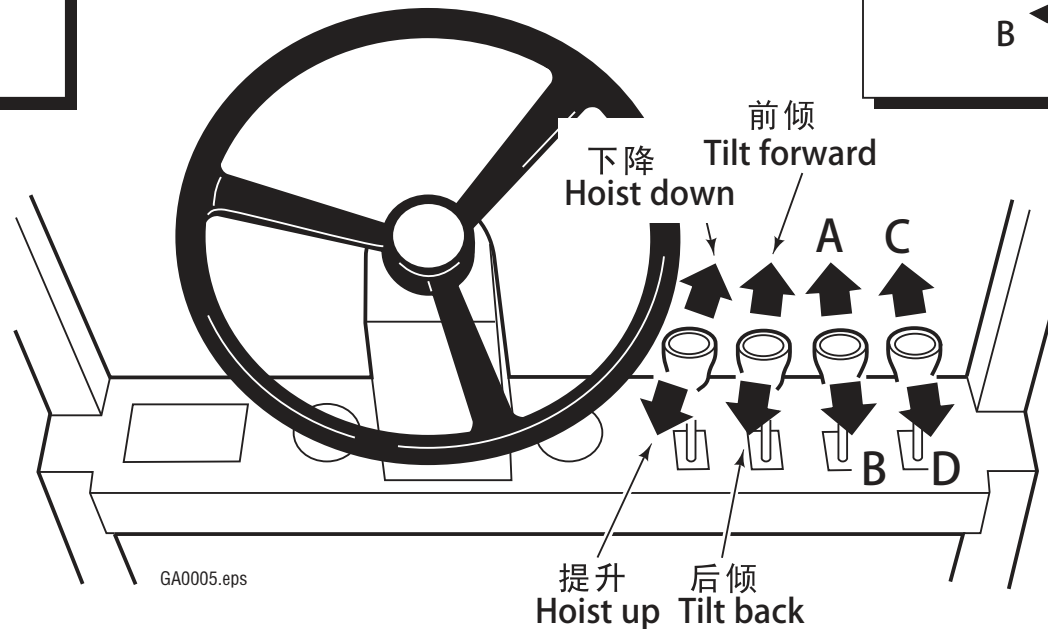
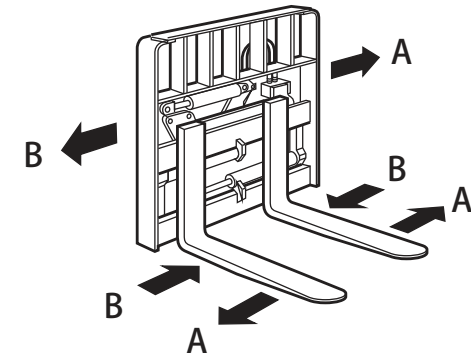

日常检查

DAILY INSPECTION

每天请检查图示项目，发现问题请及时向上级汇报。

Check items each day. Report problems to your supervisor.

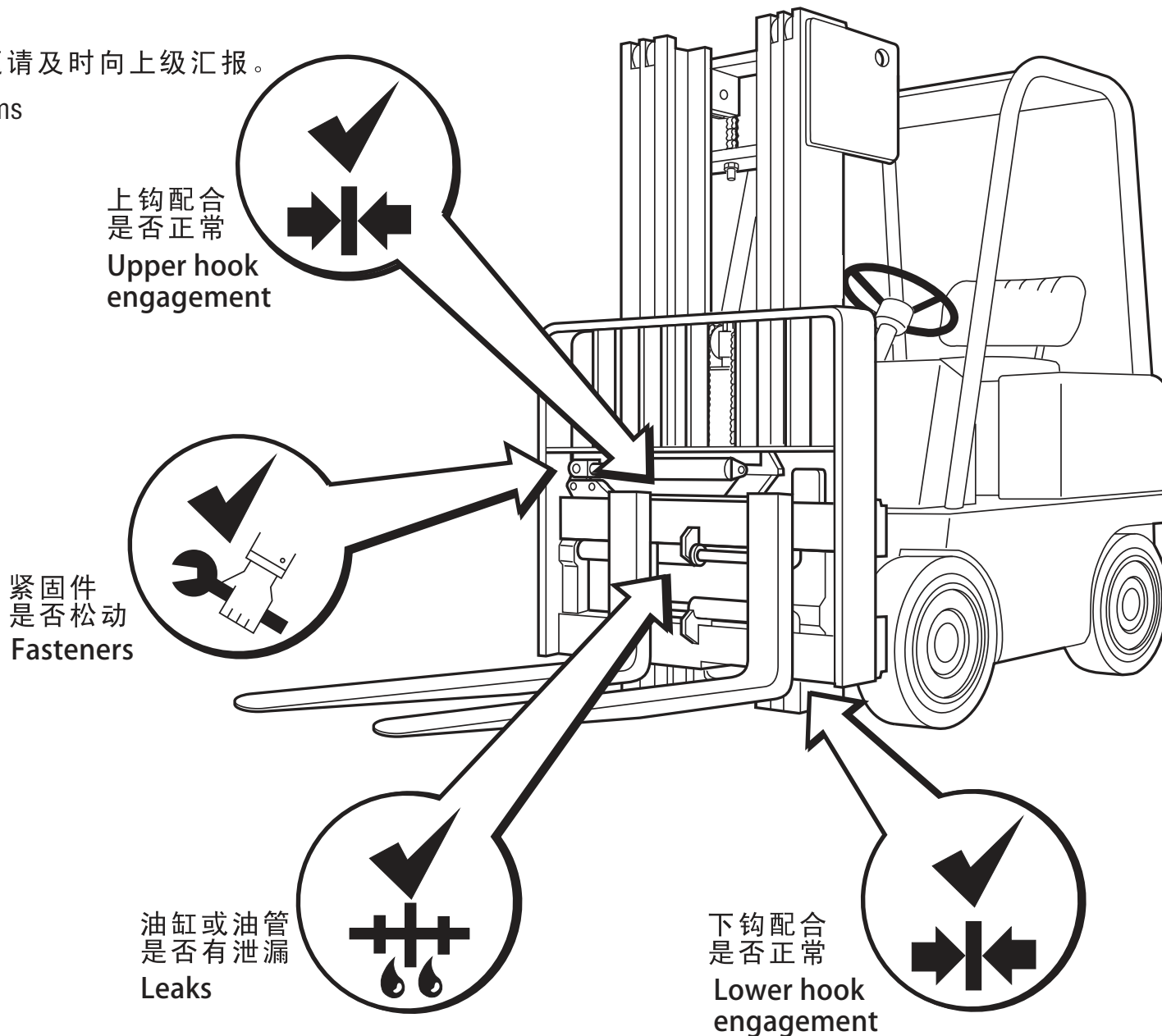

100小时保养

叉车每次维修或使用100小时后(以先到达者为准), 需完成如下检测、保养工作:

1. 检查标签或铭牌是否清晰。
2. 检查螺栓是否松动或丢失, 油管是否磨损或损坏, 油缸是否渗漏。
3. 检查货叉架下横梁与调距叉下钩的间隙。锁紧下钩螺栓: 180-200Nm

500小时保养

叉车每使用500小时后, 在进行100小时保养事项的基础上, 还应再增加以下检测、保养工作:

1. 锁紧挡货架螺栓(卡斯卡特): 155-170Nm。
2. 使用磨损测量仪(二级: 209509, 三级: 209507), 检查货叉及货叉架磨损情况。
3. 使用底盘润滑油注入上滑动支承加油嘴及货叉横梁上的滑动支承。

1000小时保养

叉车每使用1000小时后, 在进行100、500小时保养事项的基础上, 还应再增加以下检测、保养工作:

1. 检查上下滑动支承厚度, 如果低于1.5mm, 请更换。
2. 检查货叉横梁上的滑动支承厚度, 如果其外露的厚度低于1.5mm, 请更换。

2000小时保养

叉车每使用2000小时后, 在完成100、500、1000小时保养事项的基础上, 还应再增加以下检测、保养工作:

1. 更换所有上下滑动支承及货叉横梁上的滑动支承。

上滑动支承注油嘴

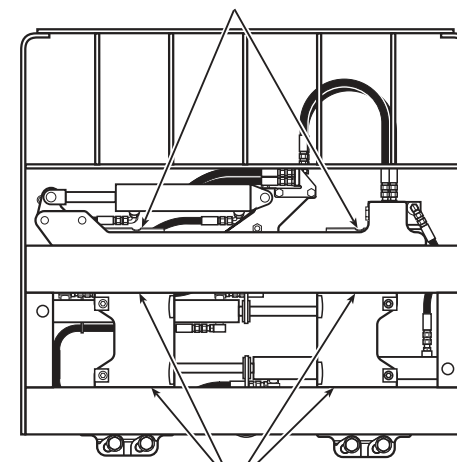

货叉横梁上的滑动支承

上滑动支承

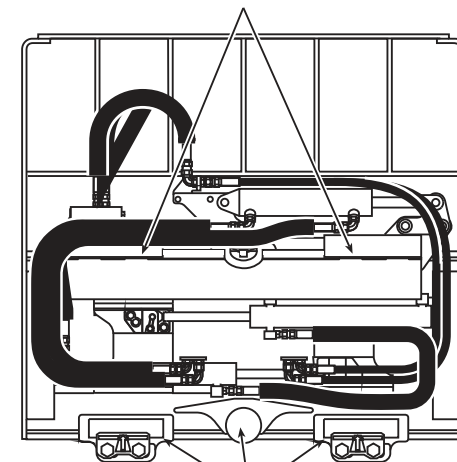

下滑动支承

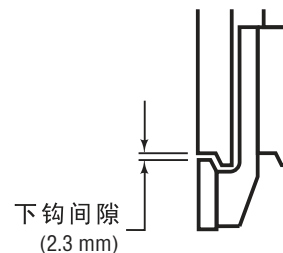

下钩间隙
(2.3 mm)

100-Hour

Every time the lift truck is serviced or every 100 hours of truck operation, whichever comes first, complete the following maintenance procedures:

1. Check decals and nameplate for legibility.
2. Check for loose or missing capscrews, worn or damaged hoses, and hydraulic leaks.
3. Inspect the clearance between the truck lower carriage bar and the fork positioner lower hooks. Tighten the lower hook bolts to a torque of 135-150ft.-lbs.

500-Hour

After each 500 hours of truck operation, in addition to the 100-hour maintenance, perform the following procedures:

1. Tighten backrest capscrews (Cascade) to 115–125 ft.-lbs
2. Check the forks and carriage for wear with wear gauge part no. 209509 (Class II) or 209507 (Class III).
3. Apply chassis grease to the upper bearing zerk fittings and fork carrier bearings.

1000-Hour

After each 1000 hours of lift truck operation, in addition to the 100-hour and 500-hour maintenance procedures, perform the following.

1. Inspect the thickness of the upper/lower bearings. If either of the bearings are worn to less than 1/16 in. thick, they should be replaced.
2. Inspect the fork carrier bearings. If the exposed thickness is less than 1/16 in. (1.5 mm), they should be replaced.

2000-Hour

After each 2000 hours of lift truck operation, in addition to the 100-hour, 500-hour, and 1000-hour maintenance procedures, perform the following procedures.

Replace the upper and lower bearing sets and fork carrier bearings..

Upper Bearing Zerk Fittings

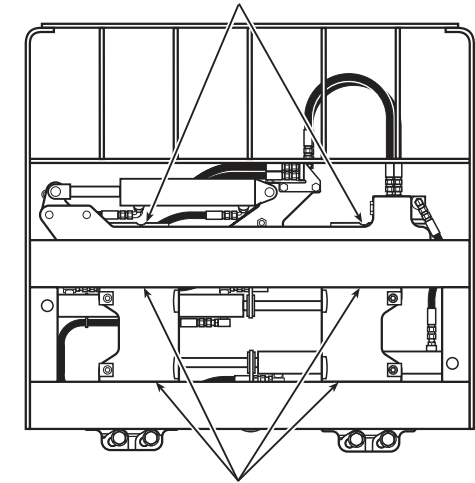

Fork Carrier Bearings

Upper Bearings

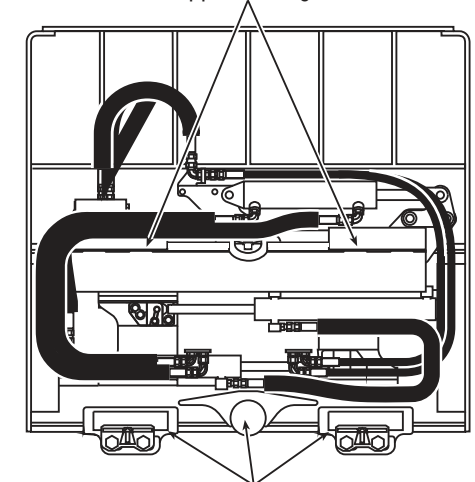

Lower Bearings

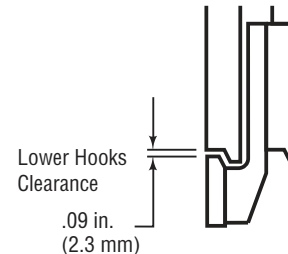

备件清单 SPARE PARTS LIST

安装总成 Mounting Group

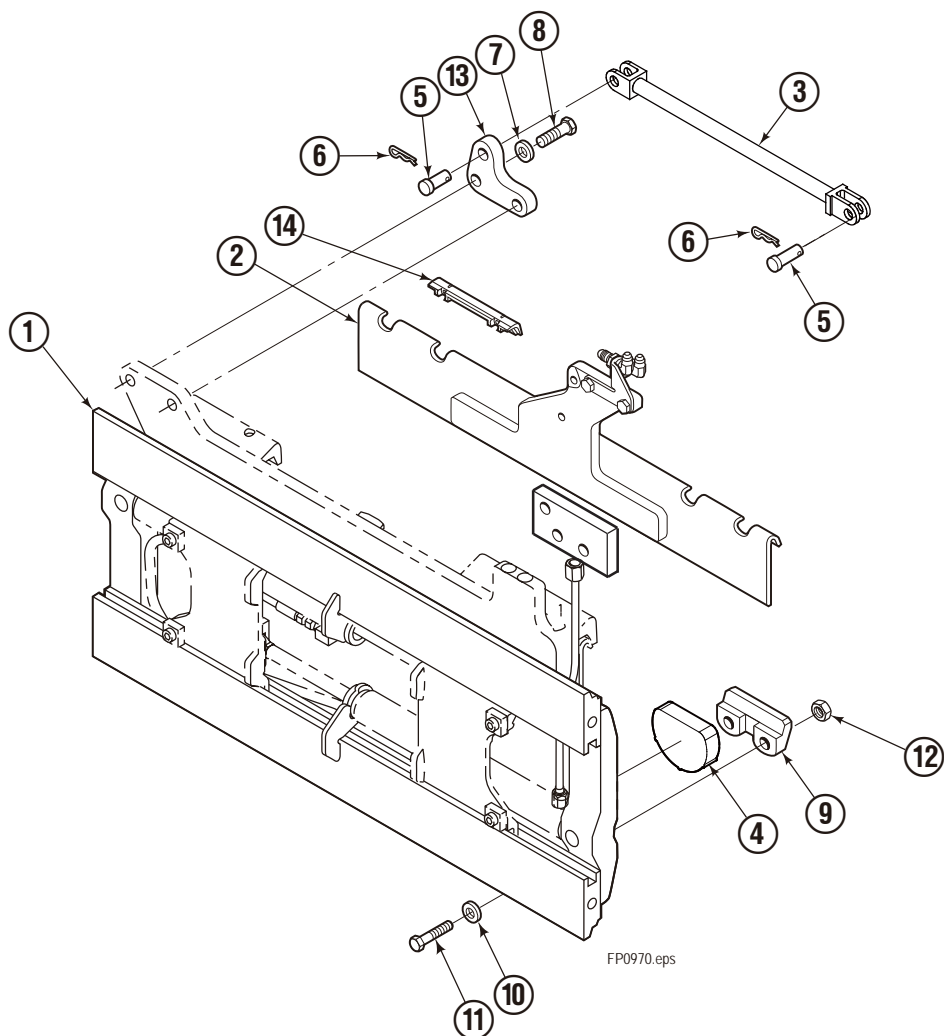

序号	数量	名称
REF	QTY	DESCRIPTION
		框架组件 Sideshifting Mounting Group
1	1	框架焊接 Frame Weldment
2	1	支架焊接 Anchor Bracket
3	1	连接杆 Connector
4	2	下滑动支承 Lower Bearing
5	2	销轴 Pin
6	2	开口销 Cotter Pin
7	2	弹簧垫圈 Lockwasher, 16
8	2	外六角螺栓 C/S-HH, M16×30
9	2	下钩 Lower Hook
10	4	垫圈 Washer, 16
11	4	外六角螺栓 C/S-HH, M16×50
12	4	锁止螺母 Nut Self-Locking, M16
13	1	缸座 Lug
14	2	上滑动支承 Upper Bearing



注：不同型号属具的上述零件具有不同的零件号，本清单所列零件号仅供参考。如需订购备件，为了确认正确的备件零件号，请事先记录下属具铭牌上的属具型号、编号等信息后，联系卡斯卡特(厦门)公司。
 Note: The Parts listed above have the different PART NO. between the different Attachment Model, this list is only for reference, when ordering replace parts, please consult us and provide the Attachment Model or Serial No. stamped on the nameplate.

备件清单 **S** PARTS LIST

液压/叉架总成 Hydraulic/Fork Group

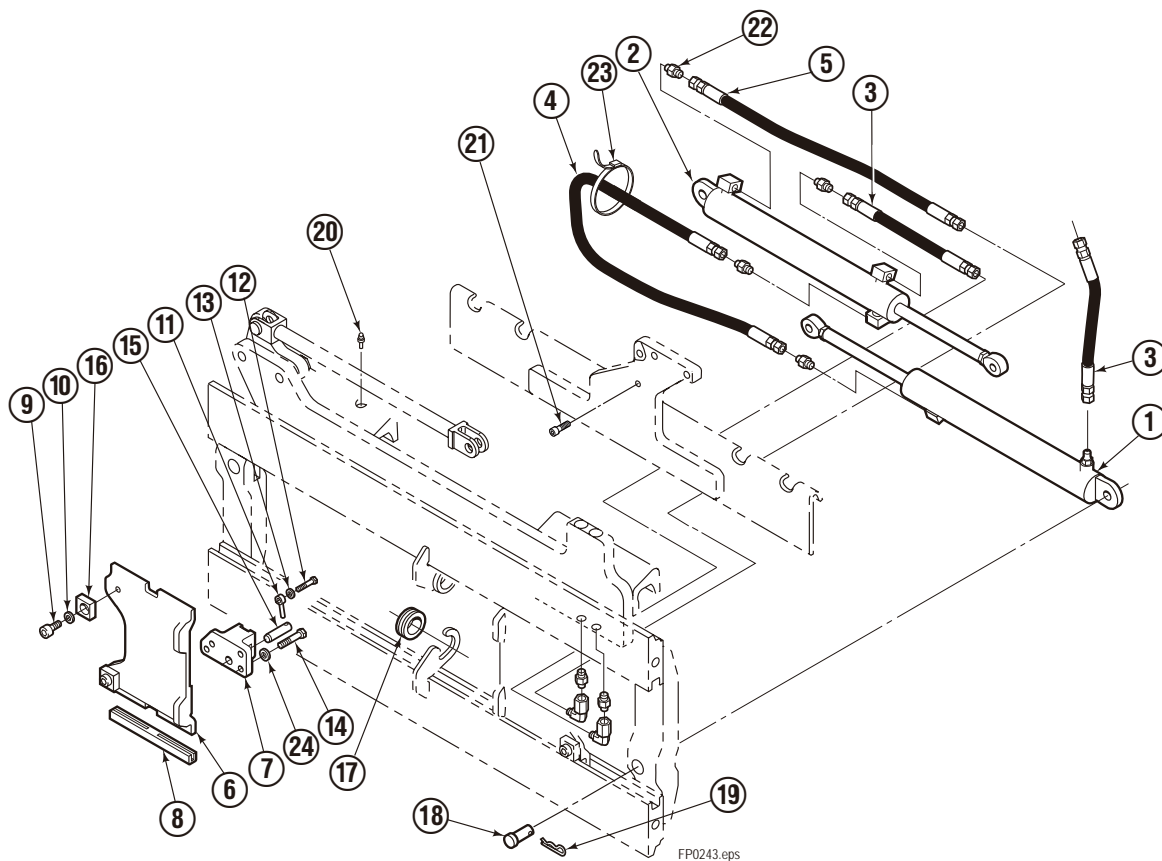

序号 REF	数量 QTY	名称 DESCRIPTION
		液压组件 Hydraulic Group
		叉架组件 Fork Group
1	1	调距油缸 (左) 总成 Cylinder Assembly - LH
2	1	调距油缸 (右) 总成 Cylinder Assembly - RH
3	2	油管 Hose, L1=345mm
4	1	油管 Hose, L2=965mm
5	1	油管 Hose, L3=686mm
6	2	叉架加工 Fork Carrier
7	2	缸座加工 Lug
8	4	滑动支承 Bearing
9	4	高强度内六角螺栓 C/S-HS, M12×20
10	4	弹簧垫圈 Lockwasher, 12
11	2	羊眼销 Eyebolt, M6×30
12	2	外六角螺栓 C/S-HH, M6×20
13	2	弹簧垫圈 Lockwasher, 6
14	8	外六角螺栓 C/S-HH, M8×16
15	2	销轴 Pin
16	4	挡块 Block
17	2	卡圈 Grommet
18	2	销轴 Clevis Pin
19	2	开口销 Cotter Pin
20	2	油咀 Grease Fitting
21	1	内六角螺栓 C/S-HS, M10×20
22	6	接头 Fitting, #4 - #4
23	1	塑料带 Cable Tie
24	8	弹簧垫圈 Lockwasher, 8



符合OSHA规则—工业车辆和属具(详见OSHA1910.178)



警告：本工业车辆安全操作和维护规则遵循OSHA1910.178和ANSI B56.1-1969工业车辆安全标准。当操作和维护安装有属具的叉车时您要特别注意这些规则的如下部分。您应熟悉这些规则的所有部分。不明之处请向您的上级询问。

(a)常规要求

- (4)除非预先得到书面许可，用户无权擅自更改和添加影响作业能力和操作安全的操作。
- (5)如果用户自行在叉车上安装属具而不通过厂家安装，用户将被要求对叉车进行标注以区别于属具，并标明在货物载荷中心夹持并举升到最大高度时叉车 / 属具准确的综合载重量。
- (6)用户在维护时应能看到所有铭牌和标签清晰明了。

(e)安全规则

- (2)如果货物堆放形式不合安全规范，用户应根据如下(a)(2)要求给叉车加装竖式挡货架。
- (a)(2)所有1972年2月15日以后用户购买的叉车的设计和结构必须符合由ANST制定ANSI B156.1-1969工业车辆部件 II 标准。

(l)操作人员培训

只有经过培训和授权的操作者才可以驾驶叉车。在叉车安全培训时应为培训人员制订相关规程。

(m)叉车驾驶

- (1)叉车不允许朝工作台或其他固定物体前的站立者行进。
- (2)叉车举升时无论空载还是载货时都不允许有人站在货叉下方或从货叉下方经过。
- (3)未经授权的人员不允许驾驶叉车，用于安全驾驶叉车的场地亦须得到许可。
- (4)不允许将手臂或脚伸到门架之间或行进着的叉车外。
- (5i)当叉车载着货停放时，货物应尽量完全放低。控制杆应挂空挡，关闭发动机并拉上制动刹车手柄。如果叉车停在斜坡上还应应用块状物挡住车轮。
- (5ii)叉车在以下情况属无人看管状态：操作者远离叉车7.6米以上（即使在视野以内），或任何时候操作者离开叉车并不在视野范围内。
- (5iii)当操作者离开叉车并在7.6米的视野范围内时，应先完全降下货物，挂空挡，关闭发动机并拉上制动刹车手柄。
- (6)在任何装卸码头或载重卡车作业时都应使叉车与斜坡或平台保持一定的安全距离。叉车不能用于开闭门。

(10)无论是否需要都应加装挡货架，以尽可能减小货物或部分货物向后掉落的可能性。

(n) 行进

(4)驾驶员经过十字路口或其他影响视野的障碍物时应慢速行驶并鸣笛。如果货物搬运时前方视线被挡，驾驶员应采用倒退搬运。

(7i)当斜坡坡度超过10°时，叉车装载行驶时须使货物相对叉车而言处于坡度上方（即上坡时叉车向前行驶，下坡时叉车倒退行驶。）

(7iii)在坡上行驶时，叉车门架尽可能后倾，并提升必要的高度以保证货物运输安全。

(o) 装货

(1)只允许搬运包装稳定或安全的货物。在搬运载荷中心不对中的货物时须小心谨慎。

(2)只允许搬运叉车承载能力范围内的货物。

(3)当货物尺寸过长或过高（包括多层货物）而影响承载能力时，必须调整货物。

(4)操作安装上属具的叉车，即使不夹持货物，也应把它看成搬运了一定重量（非满载）货物。

(5)须小心地后倾门架以保证货物稳定性。

(6)货物前后倾时要格外小心，特别是高层堆垛时。货物提升时不能同时前倾，除非叉起货物时。提升货物至堆垛货物上方时再前倾。当堆垛多层货物时，应尽量后倾以保证稳定性。

(p) 叉车操作

(1)任何时候发现叉车处于须维修、有缺陷或任何安全隐患的情况，叉车必须停下来维修直到可重新安全工作。

(q) 叉车维护

(1)任何存在不安全操作隐患的叉车都应该返修。所有维修工作应由经授权的人员完成。

(5)叉车上所有待维修更换的部件都只能用标准更换件更换以确保叉车保持出厂时的安全使用状态。

(6)未经授权不得对叉车擅自改动以避免和出厂时众多部件原有位置不符。也不允许用即使制造商原先没提供的额外部件进行更换或减少任何配件。除非得到叉车制造商的许可，否则不得对叉车超载作业。

(7)叉车投入使用前应先检查，如果检查显示任何对叉车操作不安全的迹象时都不可投入使用。这样的检查至少应每日进行。如果叉车是24小时不间断工作，那么每次换班时需例行检查。发现毛病时应立即上报并更正。



WARNING: The safe operation and maintenance of industrial trucks is regulated by Occupational Safety and Health (OSHA) regulations 1910.178 and American National Standards Institute (ANSI) Safety Standard for Powered Industrial Trucks, ANSI B56.1-1969. When operating and maintaining industrial trucks equipped with attachments you should pay particular attention to the following sections of these regulations. You should be familiar with all sections of these regulations. **Ask your employer for the complete regulations.**

(a) General Requirement

(4) Modifications and additions which affect capacity and safe operation shall not be performed by the customer or user without manufacturer's prior written approval. Capacity, operation and maintenance instruction plates, tags or decals shall be changed accordingly.

(5) If the truck is equipped with front-end attachments other than factory installed attachments, the user shall request that the truck be marked to identify the attachments and show the appropriate weight of the truck and attachment combination at maximum elevation with load laterally centered.

(6) The user shall see that all nameplates and markings are in place and maintained in a legible condition.

(e) Safety Guards

(2) If the type of load presents a hazard, the user shall equip fork trucks with a vertical load backrest extension in accordance with (a) (2) following. (a) (2) All new powered industrial trucks acquired and used by an employer after February 15, 1972 shall meet the design and construction requirements for powered industrial trucks established in the "American National

Standard for Powered Industrial Trucks, Part II, ANSI B56.1-1969", except for vehicles intended primarily for earth moving or over-the-road hauling..

(l) Operator Training

Only trained and authorized operators shall be permitted to operate a powered industrial truck. Methods shall be devised to train operators in the safe operation of powered industrial trucks.

(m) Truck Operations

(1) Trucks shall not be driven up to anyone standing in front of a bench or other fixed object.

(2) No person shall be allowed to stand or pass under the elevated portion of any truck, whether loaded or empty.

(3) Unauthorized personnel shall not be permitted to ride on powered industrial trucks. A safe place to ride shall be provided where riding of trucks is authorized.

(4) The employer shall prohibit arms or legs from being palced between the uprights of the mast or outside the running lines of the truck.

(5i) When a powered industrial truck is left unattended, load engaging means shall be fully lowered, controls shall be neutralized, power shall be shut off and brakes set. Wheels shall be blocked if the truck is parked on an incline.

(5ii) A powered industrial truck is unattended when the operator is 25 feet or more away from the vehicle which remains in his view, or whenever the operator leaves the vehicle and it is not in his view.

(5iii) within When the operator of an industrial truck is dismounted and within 25 feet of the truck still in his view, the load engaging means shall be fully lowered, controls neutralized and the brakes set to prevent movement.

(6) A safe distance shall be maintained from the edge of ramps or platforms while on any elevated dock or platform or freight car. Trucks shall not be used for opening or closing freight doors.

(10) A load backrest extension shall be used whenever necessary to minimize the possibility of the load or part of it from falling rearward.

(n) Travelling

(4) The driver shall be required to slow down and sound the horn at cross isles and other locations where vision is obstructed. If the load being carried obstructs forward view, the driver shall be required to travel with the load trailing.

(7i) When ascending or descending grades in excess of 10 percent, loaded trucks shall be driven with the load upgrade.

(7ii) On all grades the load and load engaging means shall be tilted back if applicable, and raised only as far as necessary to clear the road surface.

(o) Loading

(1) Only stable or safely arranged loads shall be handled. Caution shall be exercised when handling off-center loads which cannot be centered.

(2) Only loads within the rated capacity of the truck shall be handled.

(3) The long or high (including multiple-tiered) loads which may affect capacity shall be adjusted.

(4) Trucks equipped with attachments shall be operated as partially loaded trucks when not handling a load.

(5) A load engaging means shall be placed under the load as far as possible; the mast shall be carefully tilted backward to stabilize the load.

(6) Extreme care shall be used when tilting the load forward or backward, particularly when high tiering. Tilting forward with

load engaging means elevated shall be prohibited except to pick up a load. An elevated load shall not be tilted forward except when the load is in a deposit position over a rack or stack. When stacking or tiering, only enough backward tilt to stabilize the load shall be used.

(p) Operation of the Truck

(1) If at any time a powered industrial truck is found to be in need of repair, defective, or in any way unsafe, the truck shall be taken out of service until it has been restored to safe operating condition.

(q) Maintenance of Industrial Trucks

(1) Any power-operated industrial truck not in safe operating condition shall be removed from service. All repairs shall be made by authorized personnel.

(5) All parts of any such industrial truck requiring replacement shall be replaced only by parts equivalent as to safety with those used in the original design.

(6) Industrial trucks shall not be altered so that the relative positions of the various parts are different from what they were when originally received from the manufacturer, nor shall they be altered either by the addition of extra parts not provided by the manufacturer or by the elimination of any parts. Additional counter-weighting of fork trucks shall not be done unless approved by the truck manufacturer.

(7) Industrial trucks shall be examined before being placed in service and shall not be placed in service if the examination shows any condition adversely affecting the safety of the vehicle. Such examinations shall be made at least daily. When industrial trucks are used on a round-the-clock basis, they shall be examined after each shift. Defects when found shall be immediately reported and corrected.

质量保证政策 **W**ARRANTY

感谢您选用卡斯卡特（厦门）叉车属具有限公司产品。为了充分保障您的权益，请认真阅读本质量保证政策。

以下：“卡斯卡特（厦门）公司”指卡斯卡特（厦门）叉车属具有限公司；“购买商”指直接与卡斯卡特（厦门）公司签订产品购销合同的叉车主机厂或获得叉车主机厂授权的代理商。

卡斯卡特（厦门）公司：保证其产品符合卡斯卡特（厦门）公司所提供的有效的产品购销合同、报价单、产品手册中所列有关性能参数的要求。

卡斯卡特（厦门）公司全新产品：包括属具、货叉、卷管器和配件，质量保证期为卡斯卡特（厦门）公司货交第一承运人之日起24个月或该产品使用4000小时。以上述两项中先到期限者为准。

卡斯卡特（厦门）公司绿萌系列再制造产品：质量保证期为卡斯卡特（厦门）公司货交第一承运人之日起6个月或该产品使用1000小时。以上述两项中先到期限者为准。

本政策中，“质量保证”的含义是：卡斯卡特（厦门）公司将对于获得其书面授权人员检查后确认在材料或制造工艺方面存在缺陷的任何零部件进行修理或更换。

购买商、最终用户应做到：

- 1.在对卡斯卡特产品进行安装、调试、使用和保养时，必须严格按照相关的卡斯卡特安装说明书、检测规范、操作指南和维修手册的规定进行操作。
- 2.只有在获得卡斯卡特（厦门）公司的书面授权后，方可对所购的卡斯卡特公司产品进行修理，但不能拆除或更换产品上的零部件。任何在未经卡斯卡特（厦门）公司书面授权的情况下对卡斯卡特产品所作的修理、改动，或使用非卡斯卡特（厦门）公司原厂提供的零部件，或违反卡斯卡特安装说明书、检测规范、操作指南和维修手册中的有关规定，都将导致失去享受本质量保证政策的权利。

质量保证政策 **W**ARRANTY

注意事项:

1. 卡斯卡特（厦门）公司对于使用其产品进行超出该产品适用工况的特殊作业导致的产品损坏或任何非正常状况不予保修。
2. 当购买商或最终用户已拥有或虽未拥有但已开始使用本公司产品后，发生的该产品丢失、该产品使用中的人身或财产造成损失或损害（包括间接损失或损害），卡斯卡特（厦门）公司均不承担责任。
3. 产品正常使用中的磨损、消耗、未按卡斯卡特（厦门）公司操作指南而进行非正常使用、以及正常或定期的维护保养工作，不享受本质量保证政策。
4. 超出本质量保证政策内容及卡斯卡特（厦门）公司购销合同上所述的产品相关条款外的情况，均不享受本质量保证政策。

最终用户如果需要进一步了解卡斯卡特（厦门）公司产品或安装及修理方面的事宜，请首先向售出该产品的叉车主机厂或其代理商咨询。

卡斯卡特（厦门）公司也非常乐意解答您在这方面的任何问题。

请洽：卡斯卡特（厦门）叉车属具有限公司 服务与配件处

电话：40088 57315

本质量保证政策自2013年9月24日起生效。在新的质量保证政策颁发前，本政策一直有效。卡斯卡特（厦门）公司保留对本政策进行修改的权利，届时恕不一一通知。请注意本政策页面下端的版本号。

Version No.: Cascade Xiamen 2013

质量保证政策 **WARRANTY**

Thank you very much for your purchasing Cascade products, in order to fully guarantee your rights and interests, please read the content of this Warranty carefully.

In this article, hereafter, "Cascade Xiamen" means Cascade Xiamen Forklift Truck Attachment Co., Ltd.;"Buyer" means the forklift truck OEM (Original Equipment Manufacturer) or its authorized Dealer who signs purchasing contract with Cascade Xiamen directly for its product.

Cascade Xiamen: warrants its products to conform to published specifications as found in its valid sales contracts, quotations, brochures, price lists.

Cascade Xiamen New Products: consisting of attachments, forks, hose reels and service parts are warranted for 24 months following the date of delivery to the primary carrier, or 4000 hours of operation, whichever terminates first alternatively.

Cascade Xiamen Remanufactured Products: are warranted for 6 months following the date of delivery to the primary carrier, or 1000 hours of operation, whichever terminates first alternatively.

Within the policy, "Warranty" means Cascade Xiamen will repair or replace, at its option, any part that a Cascade Xiamen itself or authorized inspection reveals to be defective in materials or workmanship.

What Buyers and Customers must do:

- 1.To preserve Cascade Xiamen's Warranty, Buyers and Customers must carefully follow applicable Cascade Installation Instructions, Service Manuals and Operator Guides when installing, adjusting, maintaining and operating Cascade equipment.
- 2.Buyers, Customers must obtain Cascade Xiamen written authorization for repairs other than removal or replacement of defective parts.

Any unauthorized repairs or alterations, use of parts not provided by Cascade Xiamen, or failure to follow Cascade's Installation Instructions, Service Manuals and Operator Guides will result in loss of Warranty.

Notice:

- 1.Cascade Xiamen does not warrant that its products will perform any particular task which conditions are not suitable for the product.
- 2.Cascade Xiamen assumes no responsibility for loss, damage or injury to persons or property, or for consequential damages, resulting from the possession or use of its products.
- 3.Cascade Xiamen's Warranty does not cover wear, tear, abnormal applications which fail to follow Cascade Xiamen product Operator's Guide properly, normal or scheduled maintenance.
- 4.**THERE ARE NO WARRANTIES EITHER EXPRESS OR IMPLIED INCLUDING ANY WARRANTY OF FITNESS FOR A PARTICULAR PURPOSE WHICH EXTEND BEYOND THOSE STATED IN THIS WARRANTY AND THE PRODUCT DESCRIPTION ON THE FACE OF CASCADE XIAMEN'S ORDER ACKNOWLEDGEMENT.**

If the end user customer would like to know more about Cascade Xiamen product or the relevant aspects of installation and service, please firstly consult with the forklift truck OEM or its Dealer who sold the product.

Cascade Xiamen is also very happy to answer any of your questions on this. Please contact: Service and Spare Parts Department, Cascade Xiamen Forklift Truck Attachment Co., Ltd. Phone: 40088 57315

This Warranty's effective since September 24, 2013. Its validity remains until being superceded by a later version. Cascade Xiamen reserves all the rights of amendment without notice. Please note the Version No. at the bottom of this page.

Version No.: Cascade Xiamen 2013

卡斯卡特（厦门）叉车属具有限公司
Cascade Xiamen Forklift Truck Attachment Co., Ltd

地址：厦门市海沧区阳光路668号 邮编：361026

No.668 Yangguang Road, Haicang, Xiamen, Fujian ,361026 P.R China

电话/Tel: 0592-6512570 传真/Fax: 0592-6512571

cascade corporation

www.cascorp.com.cn

卡斯卡特（厦门）公司保留对本公司修改的权利，如有修改，恕不另行通知。

Cascade Ximen reserves the rights to make change without notice.

1210979 R2 xm cn 04/2015